



Skylight Shading System Installation Guide



BTG 491209

We make it easy!

Before starting

Your new Blinds To Go® shade is custom made to your specifications from the finest material available. To ensure proper functioning of your shade, it is extremely important to follow these guidelines.

Note: Mounting screws provided are suitable for most mounting surfaces. See below for additional suggestions.

For wallboard or plaster: Use hollow wall anchors provided for added support.

For concrete, stone, brick or tile: Use a carbide drill and appropriate anchors before fastening the screws.

For metal surfaces: Pre-drill holes before fastening the screws.

Suggested Tools

- Drill
- Pencil
- Scissor
- Tape Measure
- Flathead Screwdriver

Anatomy of the Skylight Shading System

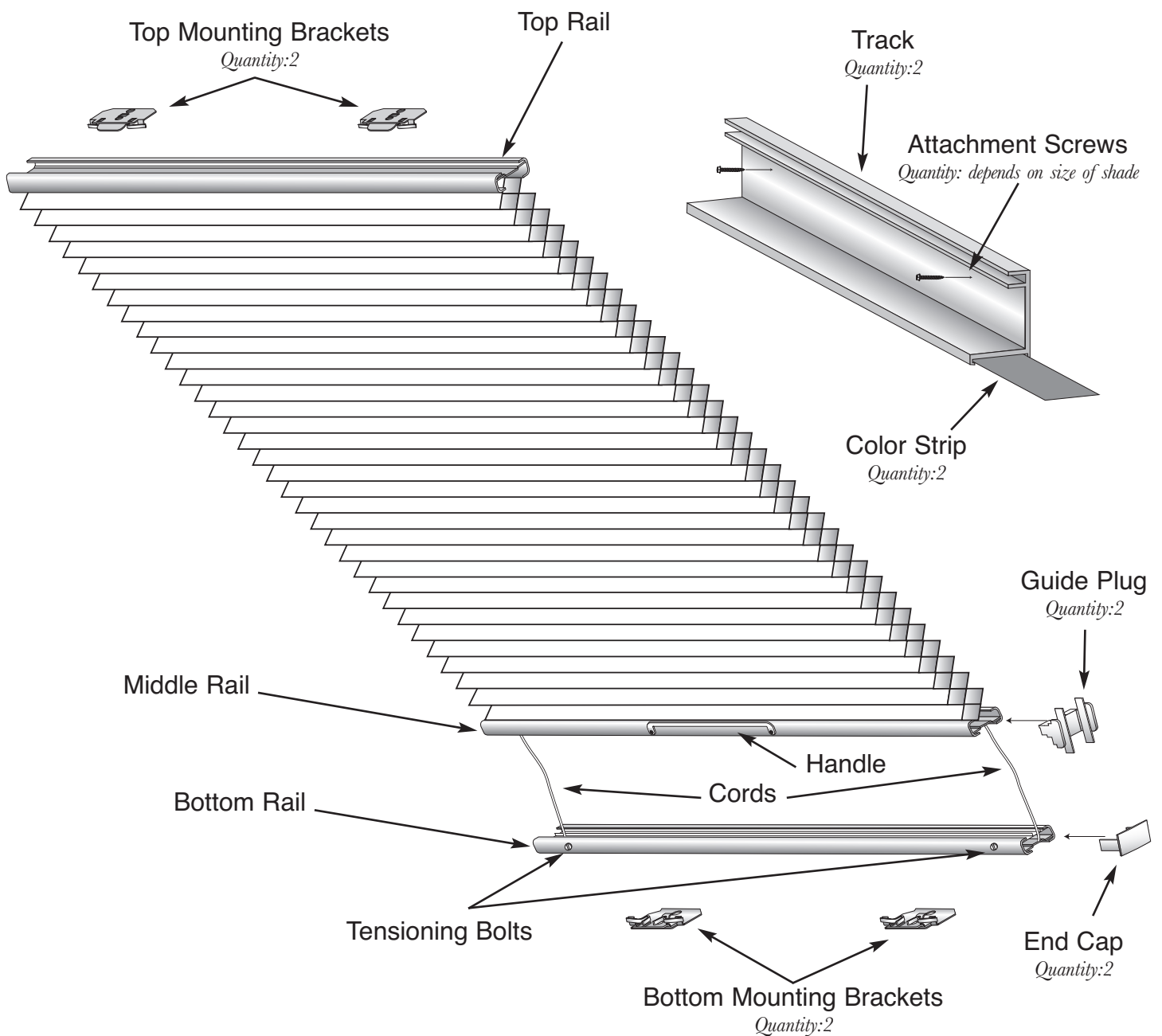

Getting started

Important: to ensure proper functioning of your shade, it is extremely important to follow these guidelines.

Step 1. Installing tracks

1. (See Fig. A&B) Mark the screws positions with a pencil on the inside of the tracks. The screws should be $\frac{3}{4}$ " from the front edge of the track. The two end screws should be 4" in from each end and approximately 12" apart for intermediate screws.
2. Position the tracks so they are parallel and their back is at least $\frac{3}{4}$ " from any obstruction.
3. Pre-drill holes through the tracks and into window frame according to pencil marks. Install the tracks with screws provided.

Top Bracket Spacing Chart

Shade Width	Top Bracket Location
15"-20"	2 $\frac{1}{2}$ "
20"-32"	4 $\frac{1}{2}$ "
32"-48"	6 $\frac{1}{2}$ "

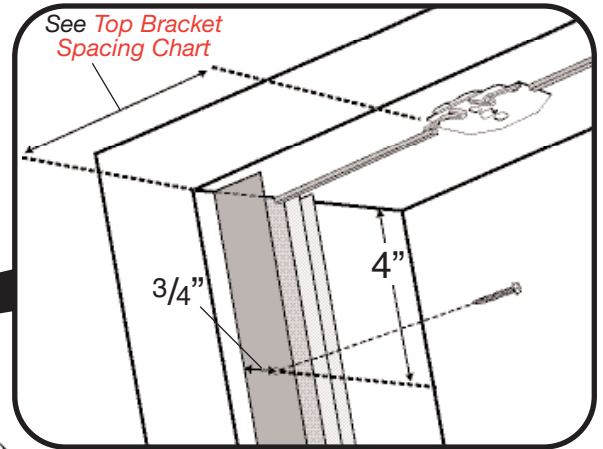

Fig. B

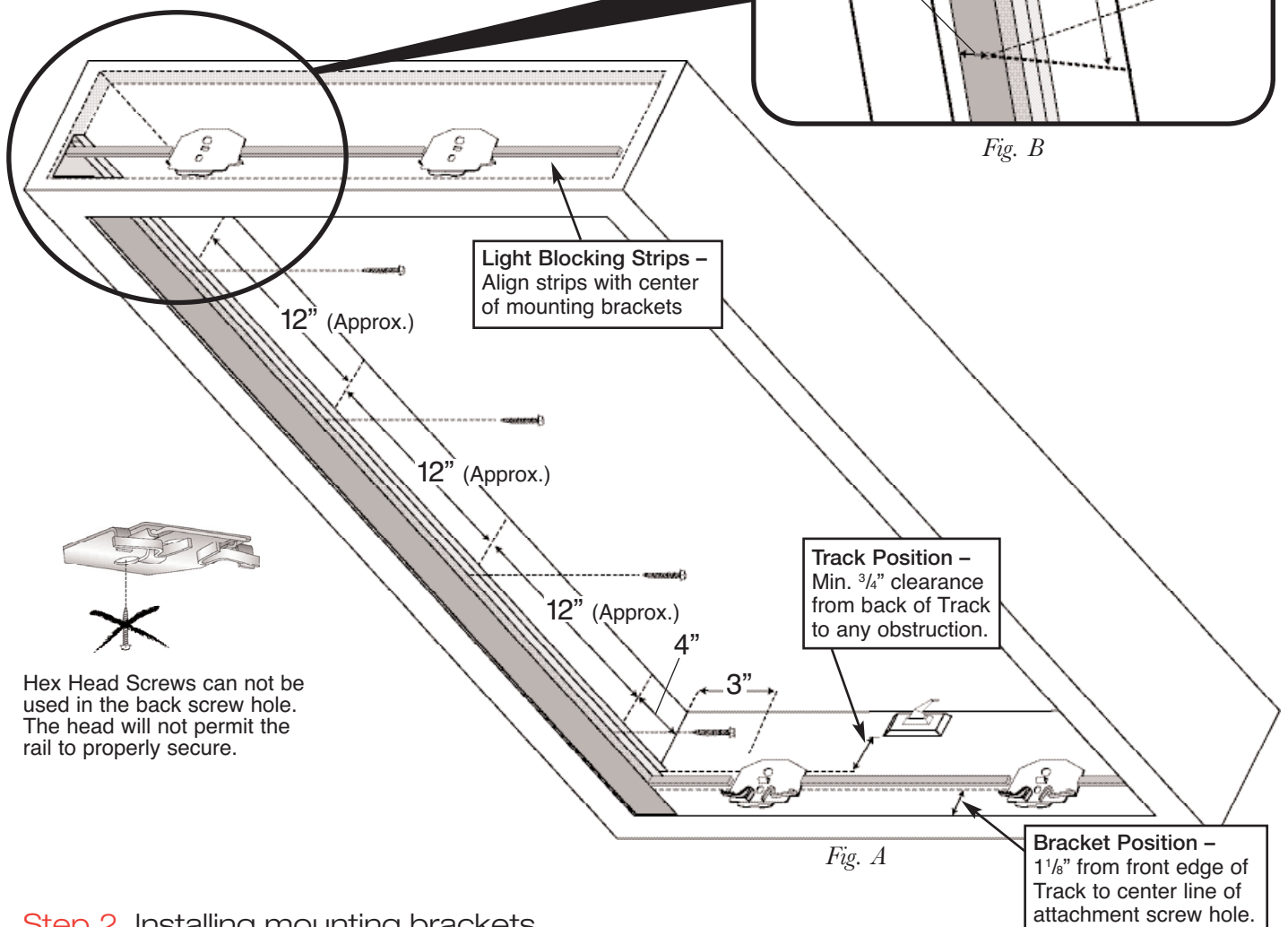

Fig. A

Step 2. Installing mounting brackets

Mounting brackets should be positioned so that the center of their front screw hole is 1 $\frac{1}{8}$ " back from the front edge of the tracks. It is critical that the brackets are aligned.

1. Top brackets' location depends on the width of the shade. Refer to "Top Bracket Spacing Chart".
2. Bottom brackets should be positioned 3" in from the tracks.

Step 3. Applying light blocking strips

Note: do not remove the back liner until the strips are cut to length.

1. Measure the distance between mounting brackets, and between brackets and window casing, both on top and bottom.
2. Cut the Light Blocking Strip into 6 pieces to fit into the 6 spaces just measured.
3. Remove the back liner from the strips and apply them firmly in position, aligning the strips with the center of the brackets.

Step 4. Installing shade into tracks

1. Compress top and middle rails. Make sure the cords are hanging freely and do not interfere with the guide plugs.
2. Insert one guide plug into each end of middle rail.

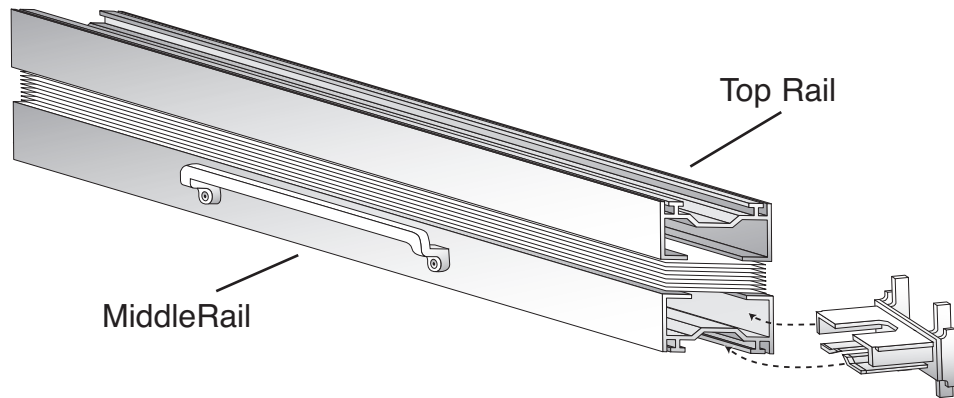

3. Apply a small amount of provided grease inside track groove for smooth operation. Save any leftover grease in case future application is needed.
4. Tilt shade and place it between tracks. Insert one side of middle rail at a time by inserting back side of guide plug into track groove.

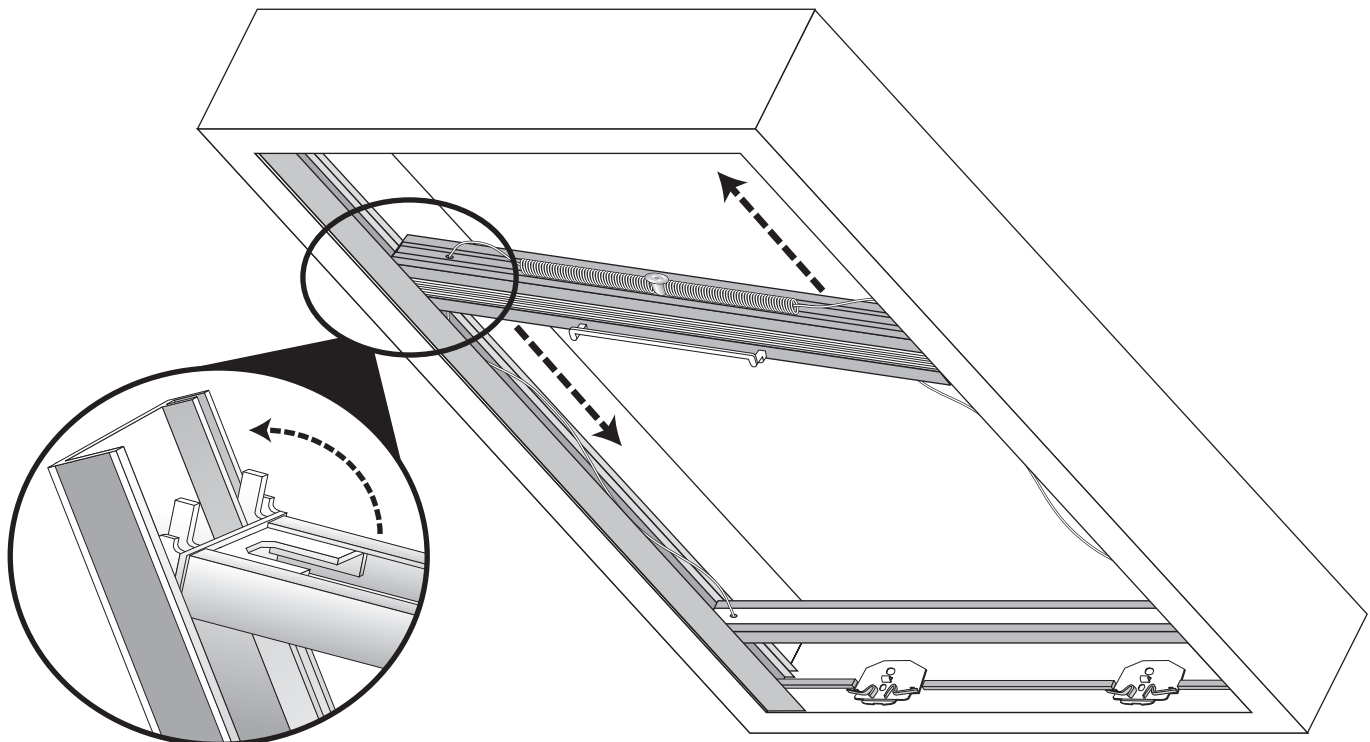

5. Hold top and middle rail tightly and push guide plugs all the way into track groove until you hear three clicks for each plug. Make sure the guide plugs are square to the tracks for smooth operation.

Step 5. Securing shade into brackets

1. Slide middle and top rails up to top mounting brackets.
2. Fit front lip of the brackets into front groove of top rail.
3. Push top rail back until the back groove snaps onto back hooks of the bracket.

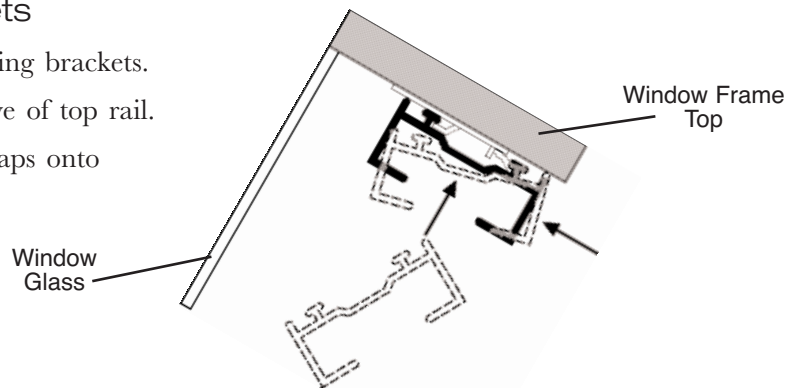

4. Secure the bottom rail to bottom brackets in the same manner.
5. Slide the middle rail up and down a few times to see if the operation is smooth. If it is not, check if the tracks are parallel, the brackets are aligned and there is sufficient grease in the track grooves.

Step 6. Adjusting cord tension

1. Raise the middle rail to the top rail, compressing the fabric stack tightly.
2. Hold the middle rail in position and adjust the Tensioning Bolts one at a time with a flat head screwdriver. Turn clockwise to tighten and counterclockwise to loosen.

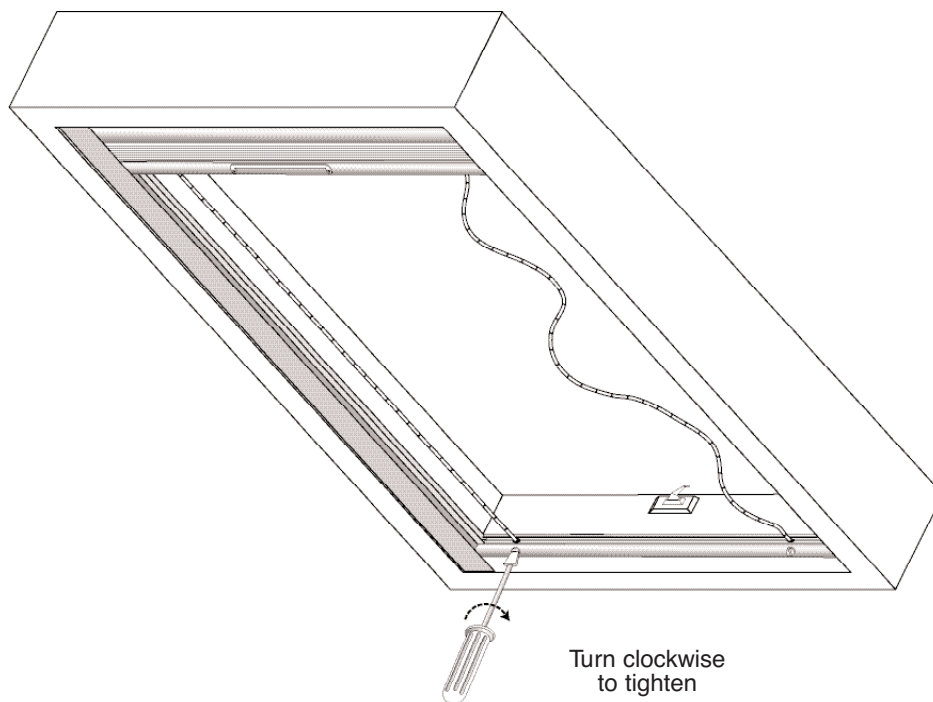

3. Adjust the cords until all slack is removed, but cords are not too tight.
4. Try open and close the shade fully a few times. If the shade won't stay all the way opened or closed, increase the amount of tension in each side equally by making the same number of turns. If the shade feels tight or is difficult to move, decrease the same amount of tension in each cord. If the Middle Rail won't close evenly across the Bottom Rail, then adjust one or both of the cords to get equal tension in each.
5. Operate the shade up and down a few times to evenly distribute the grease. Wipe off any excess grease to prevent it from getting on fabric.

Troubleshooting

PROBLEM	REASON	SUGGESTED REMEDY
Middle Rail difficult to move.	<p>Tension too tight in cords.</p> <p>Screws in track interfering with Guide Plugs.</p> <p>Guide Plugs not inserted into Track properly.</p> <p>Insufficient lubrication.</p> <p>Shade too wide.</p>	<p>Loosen Tensioning Bolts.</p> <p>Reposition screws $\frac{3}{4}$" back from front edge of Tracks.</p> <p>Make sure Guide Plugs are pressed into Track as far as possible and that the top and bottom of each plug is inserted the same amount.</p> <p>Apply provided grease.</p> <p>Recheck width dimensions. If a cutdown is required, contact the showroom where the purchase was made.</p>
Middle Rail won't stay opened or closed.	Tension too loose in cords.	Tighten Tensioning Bolts (a quarter turn at a time).
Middle Rail not level with Bottom Rail.	Unequal tension in Tensioning Bolts.	<p>Method 1:</p> <p>Move Middle Rail up to Top Rail, compressing fabric. Adjust one or both Tensioning Bolts to obtain equal tension.</p> <p>Method 2:</p> <p>Move Middle Rail down to Bottom Rail. Adjust one or both Tensioning Bolts to make Middle Rail parallel with Bottom Rail.</p>